



PLASTIC SCRAP GRINDERS

WELL GRIND series

Salient features:

- Heavy duty construction
- Hardened/ground cutting blades are provided with optimum cutting rakes to grind softest to hardest plastic.
- Rotor mounted on heavy duty double ball bearings on both sides.
- Circular saw for cutting large plastic articles before grinding, available as optional.

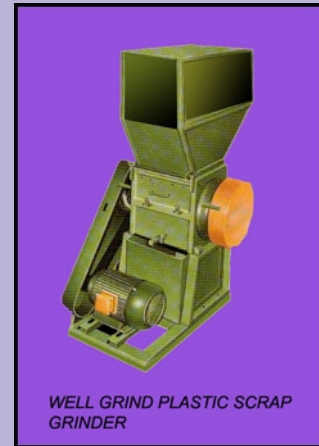

Models	WG-1	WG-5	WG-75	WG-100
Blade length (mm)	75mm	250mm	300mm	375mm
No: of blades:				
Rotating	2	2	4	4
Stationery	4	4	4	4
Throughput/hr approx.	40 Kg	7.5HP	125 Kg	200 Kg
Approx. Dimensions mm	500x525x1000H	625x600x1250H	700x675x1400H	1400x800x1500H
Un-packed weight approx.	175 Kg	275 Kg	325 Kg	600 Kg
H.P of motor AC	1 HP	5 HP	7.5 HP	10 HP

Note: Throughput depends on type of material and mesh opening.

Manufacturers:

MALIK ENGINEERS

Unit-1, Shailesh Ind. Estate-1, Navghar, Vasai(East)-401 210, M.S., India. Telefax: 91 250 390839
 Off: B-203, Atlanta, Evershine nagar, Malad(West),Mumbai-400 064, India. Telefax: 91 22 8830751
 Email: info@malikengg.com website: www.malikengg.com